

## Quad 303 Fully Symmetrical Output Stage Notes

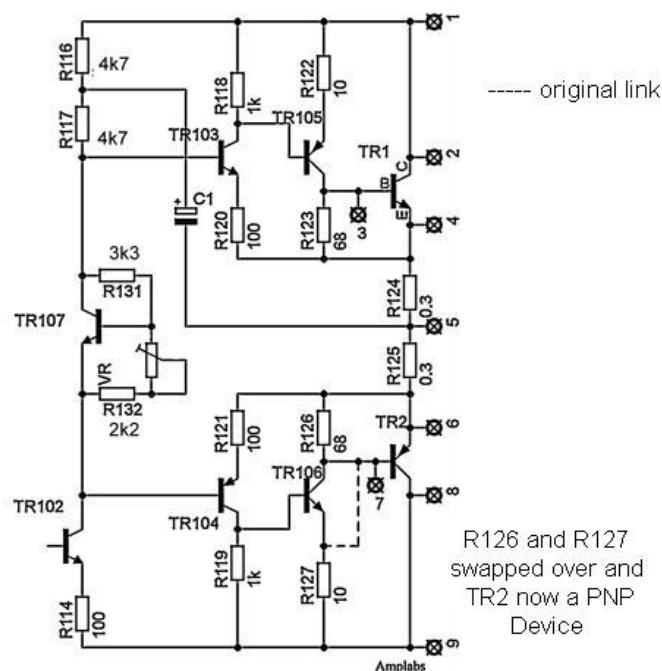

- 1/ TR1 and TR2 are changed to Complimentary pairs e.g. MJ15003 (NPN) and MJ15004 (PNP)
- Resistors R127 and R126 are interposed on the board using new resistors.
- The track between R127 and Tag 7 is cut with at least a 5mm gap.
- Tag 7 is now linked to TR106 collector instead of the emitter using a short wire.
- Compensation capacitors may be added if necessary, to prevent HF instability due to the better HF performance of modern transistors like the MJ15003/4.
- The modified circuit is shown above. The dotted line shows where the original track went.